



Model Number: APS-450nm-3000mW-MTM-9.0mm-CC-Z

APS 3000 mW 450 nm Laser Diode Module With Adjustable Aspheric Collimating Lens

Absolute Maximum Ratings at 25 °C

Item	Ratings	Unit
CW Output Power	3200	mW
Laser Diode Reverse Current	20	mA
Maximum Operating Current	2300	mA
Operating Temperature	0 to 85	°C
Storage Temperature	-20 to 120	°C

- Simple Integrated Package
- Excellent Diode Heatsinking
- Small Footprint
- Simple Connection With Two Power Leads
- Adjustable Collimating Lens
- Lightweight, Rugged
- Precision Machined

**Applications: Laser Engraving, Marking,
Pumping Ti:Sapphire, Pr:YLF, Other
Solid-State Lasers**



Advanced Photonics Sciences, LLC. Tel.: 570-553-1120

www.advancedphotonicsciences.com

info@advancedphotonicsciences.com



Model Number: APS-450nm-3000mW-MTM-9.0mm-CC-Z
APS 3000 mW 450 nm Laser Diode Module With Adjustable Aspheric Collimating Lens

Optical and Electrical Characteristics at 25 °C

Parameter	Min	Typical	Max	Units	Test Condition
Threshold Current	-	270	450	mA	-
Operating Current	-	1900	2300	mA	$P_o = 3000 \text{ mW}$
Operating Voltage	-	-	5.5	V	$P_o = 3000 \text{ mW}$
Fast Axis Beam Divergence	-	49	-	°	$P_o = 3000 \text{ mW}$ 1/e ² Full Angle
Slow Axis Beam Divergence	-	7	-	°	$P_o = 3000 \text{ mW}$ 1/e ² Full Angle
Lasing Wavelength	437	-	460	nm	$P_o = 3000 \text{ mW}$
Transverse Mode	MTM	MTM	MTM	-	All Currents
Polarization TE	-	-	-	-	Horizontal

Module Experimental Data

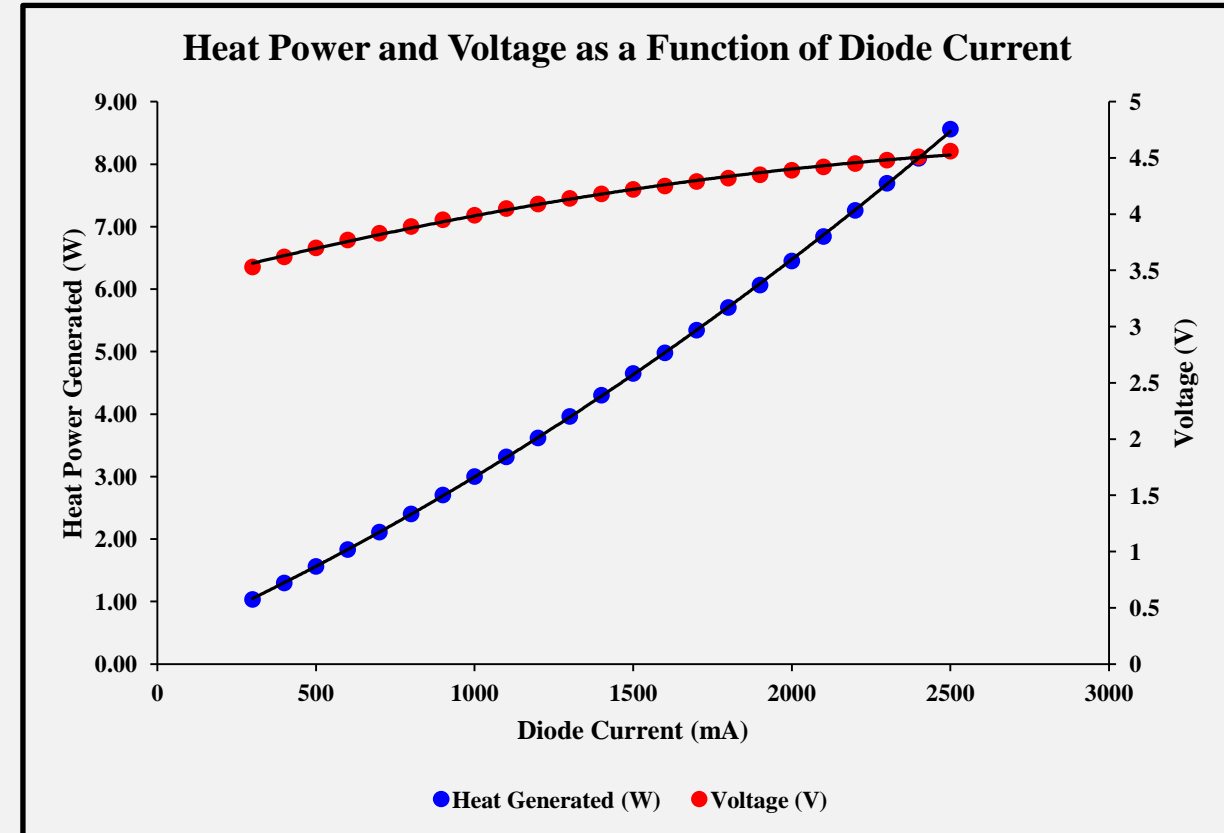
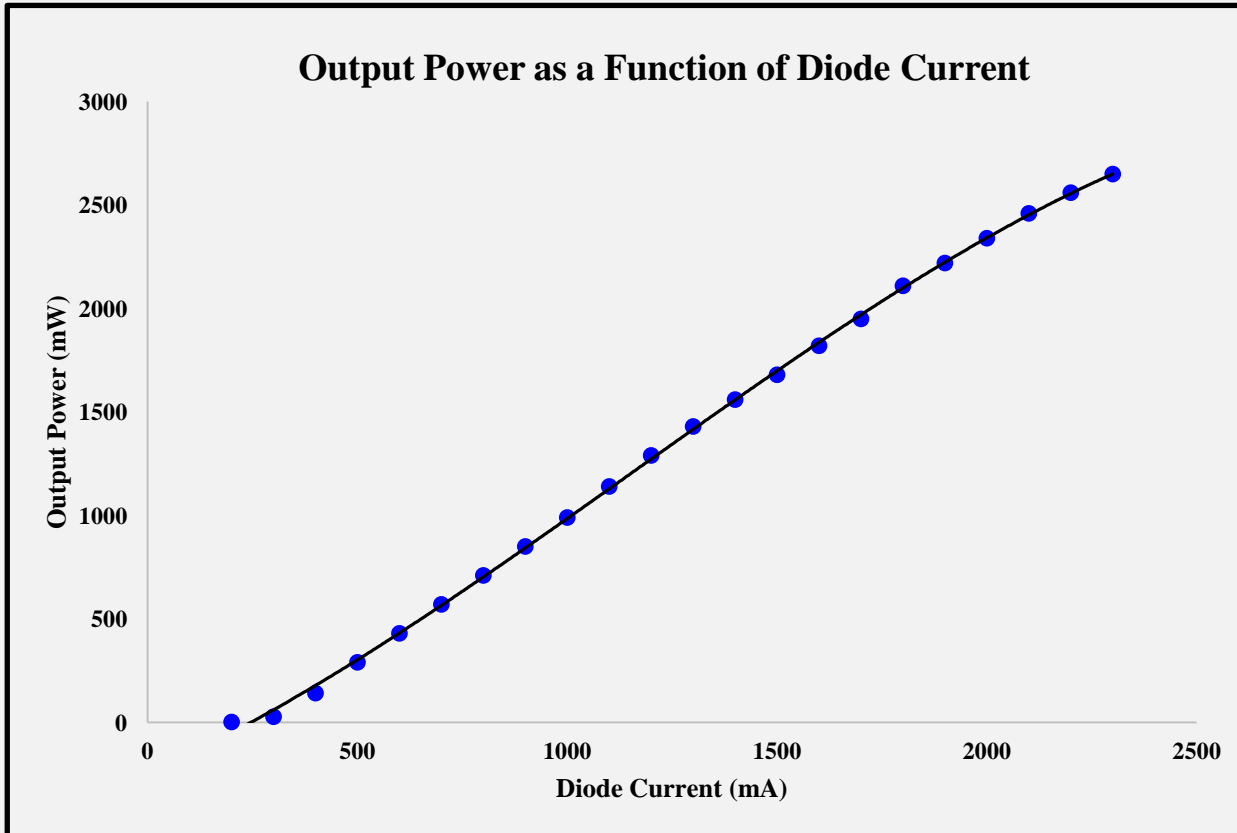

Module Experimental Data

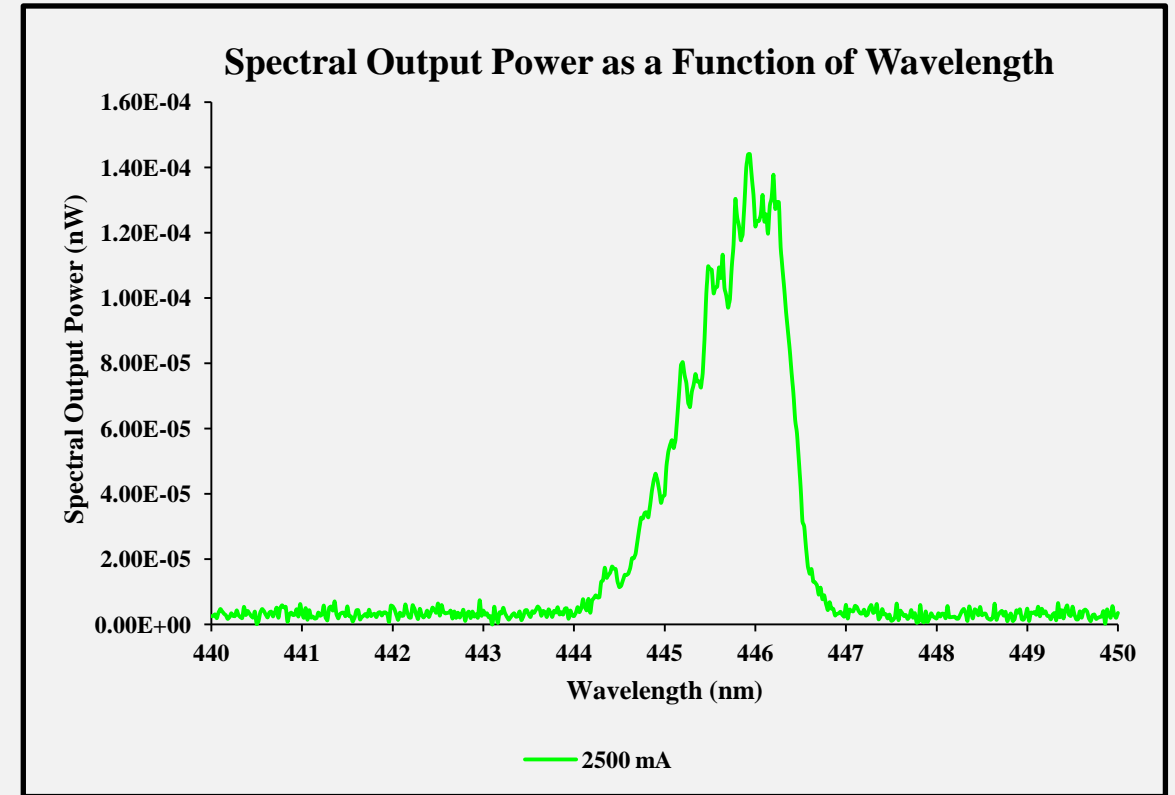
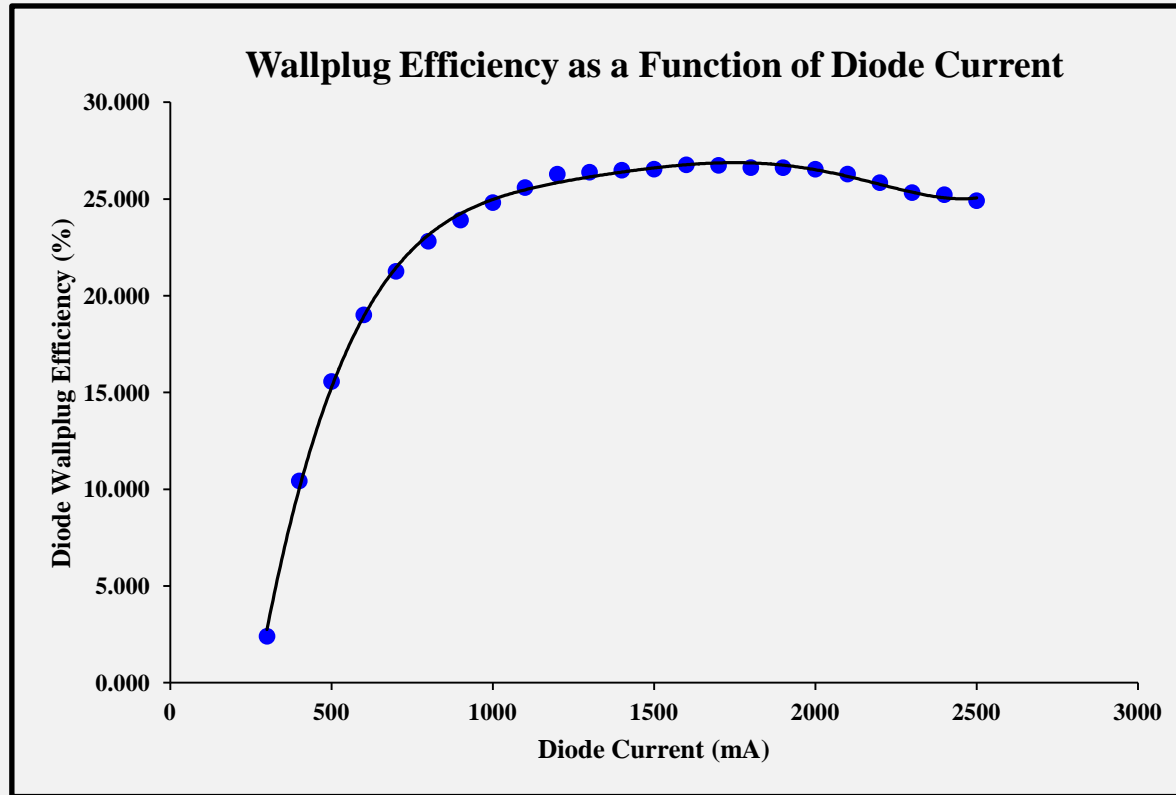

Model Number: APS-450nm-3000mW-MTM-9.0mm-CC-Z

Module Dimensions and Mounting Screws

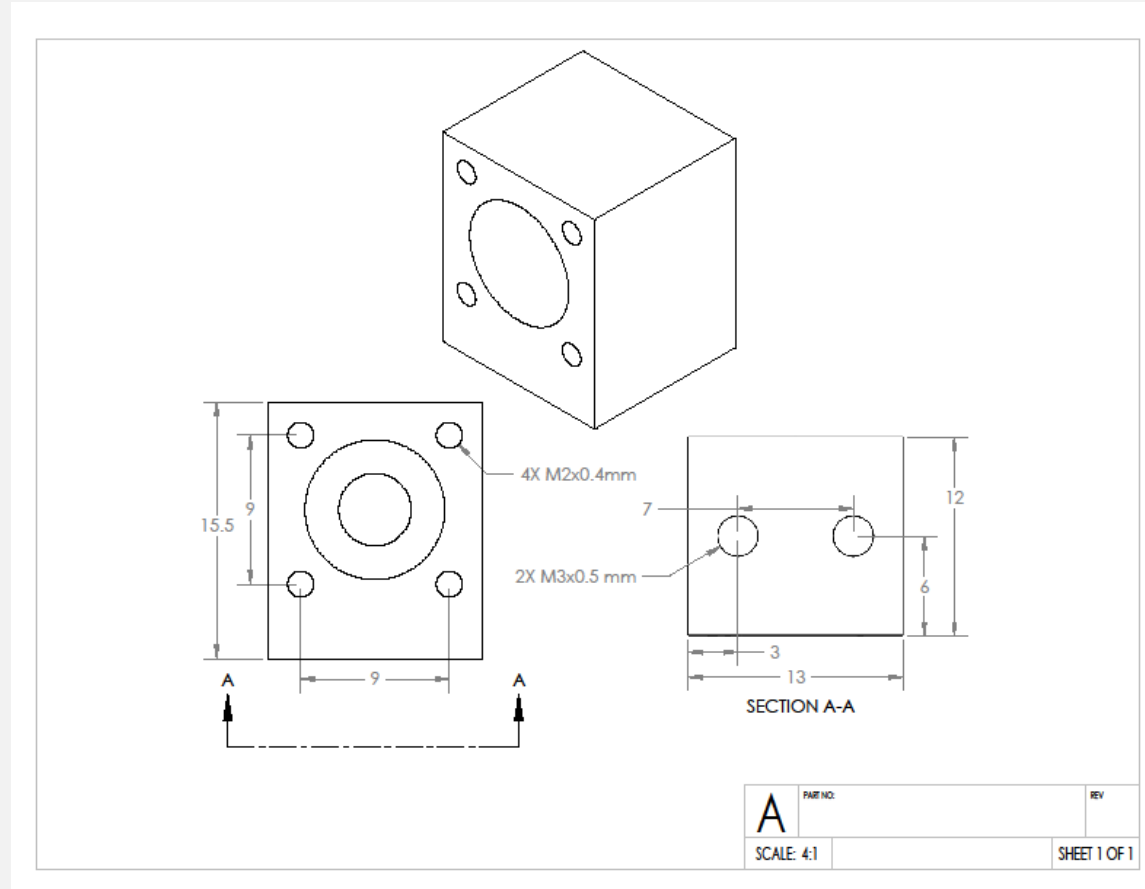



Model Number: APS-450nm-3000mW-MTM-9.0mm-CC-Z

Laser Safety Warnings

- **This OEM Micro-Module is meant for integration into other systems, and as such is not CDRH compliant.**
- **This Micro-Module is a Class 4 laser product.**
- **Always use laser safety glasses with sufficient Neutral Density at the operating wavelength of 450 nm to protect your eyes.**
- **Skin exposure to this laser product should be avoided.**