



Model Number: APS-980nm-250mW-STM-9.0mm-CC

APS 250 mW 980 nm Laser Diode Module With Adjustable Aspheric Collimating Lens

Absolute Maximum Ratings at 25 °C

Item	Ratings	Unit
CW Output Power	250	mW
Laser Diode Reverse Voltage	2	V
Maximum Operating Current	340	mA
Operating Temperature	-20 to 50	°C
Storage Temperature	-40 to 80	°C

- **Simple Integrated Package**
- **Excellent Diode Heatsinking**
- **Small Footprint**
- **Simple Connection With Two Power Leads**
- **Adjustable Collimating Lens**
- **Lightweight, Rugged**
- **Precision Machined**

Applications: Pointing, Illumination

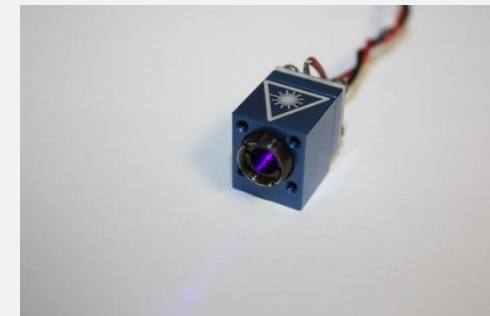



Model Number: APS-980nm-250mW-STM-9.0mm-CC

APS 250 mW 980 nm Laser Diode Module With Adjustable Aspheric Collimating Lens

Optical and Electrical Characteristics at 25 °C

Parameter	Min	Typical	Max	Units	Test Condition
Threshold Current	-	30	50	mA	-
Operating Current	-	300	340	mA	$P_o = 250 \text{ mW}$
Operating Voltage	-	1.7	2.0	V	$P_o = 250 \text{ mW}$
Fast Axis Beam Divergence	-	51	54	°	$P_o = 250 \text{ mW}$ 1/e ² Full Angle
Slow Axis Beam Divergence	-	14	18	°	$P_o = 250 \text{ mW}$ 1/e ² Full Angle
Lasing Wavelength	975	980	985	nm	$P_o = 250 \text{ mW}$
Transverse Mode	STM	STM	STM	-	All Currents
Polarization TE	-	-	-	-	Horizontal

Module Experimental Data

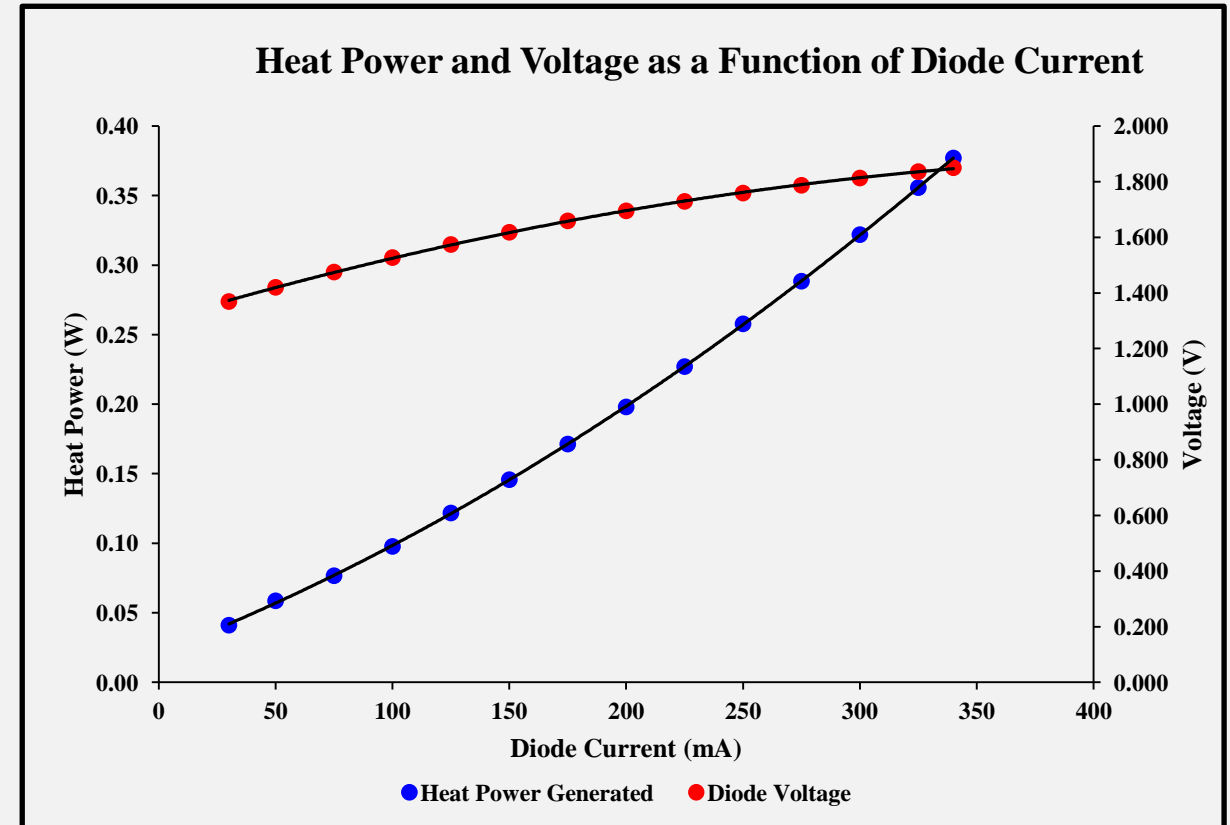
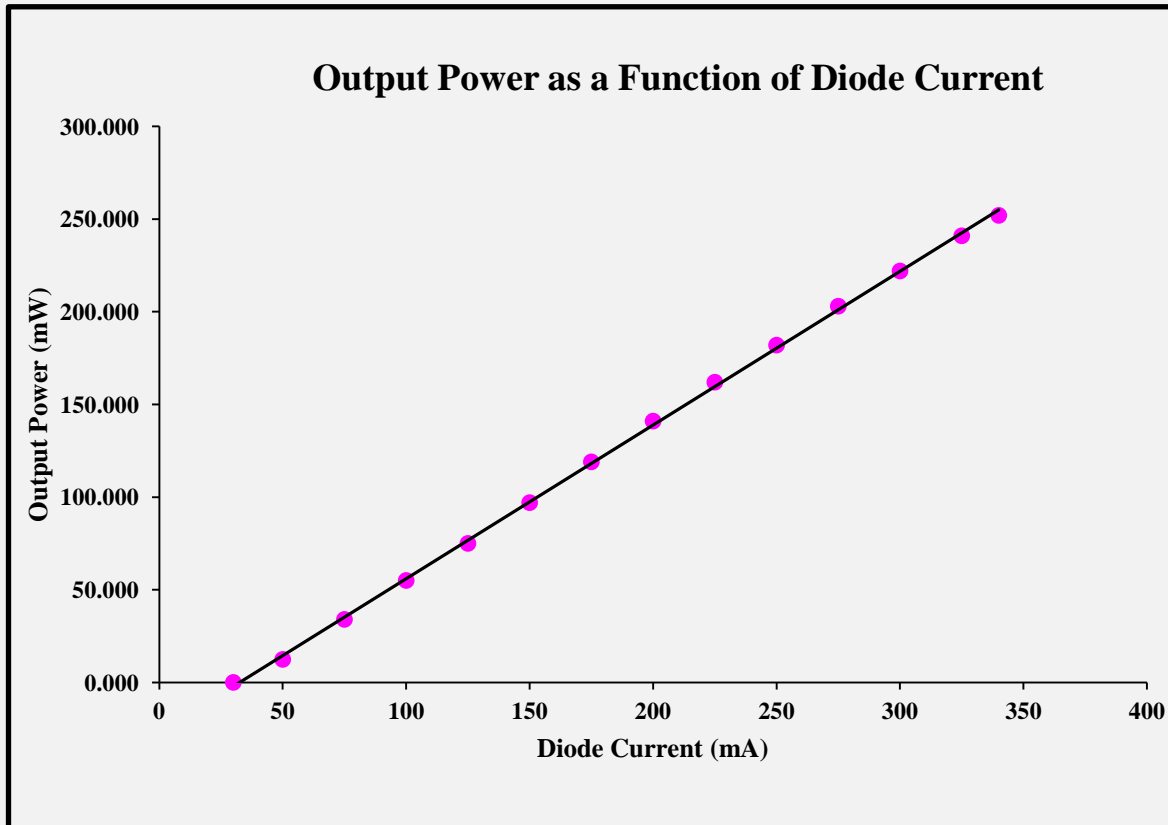

Module Experimental Data

Wallplug Efficiency as a Function of Diode Current

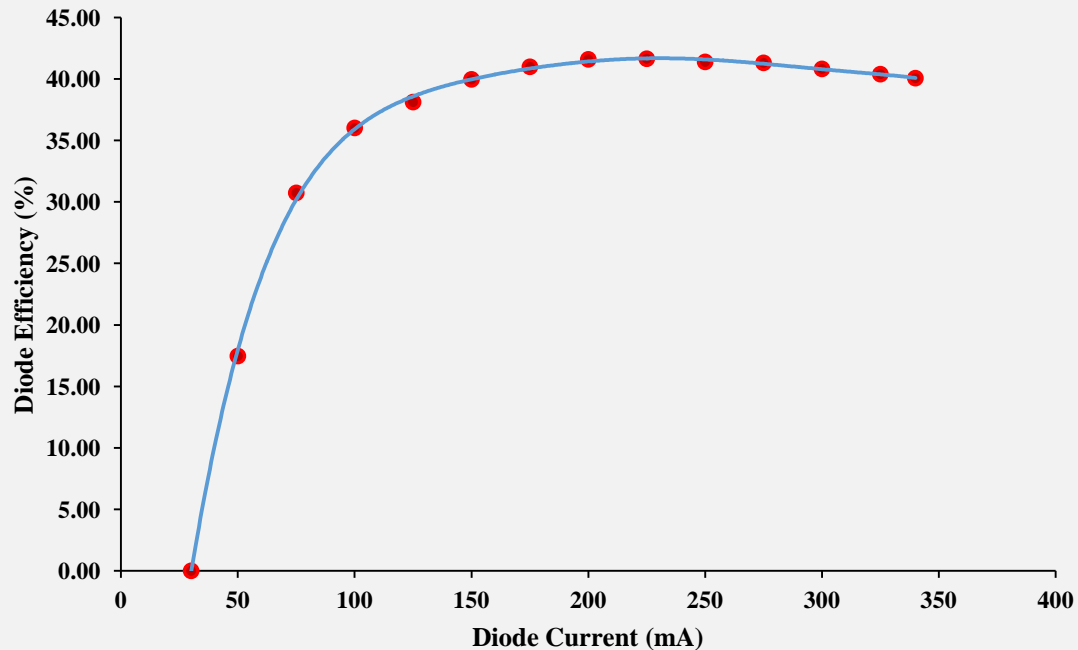

Spectral Output Power as a Function of Wavelength

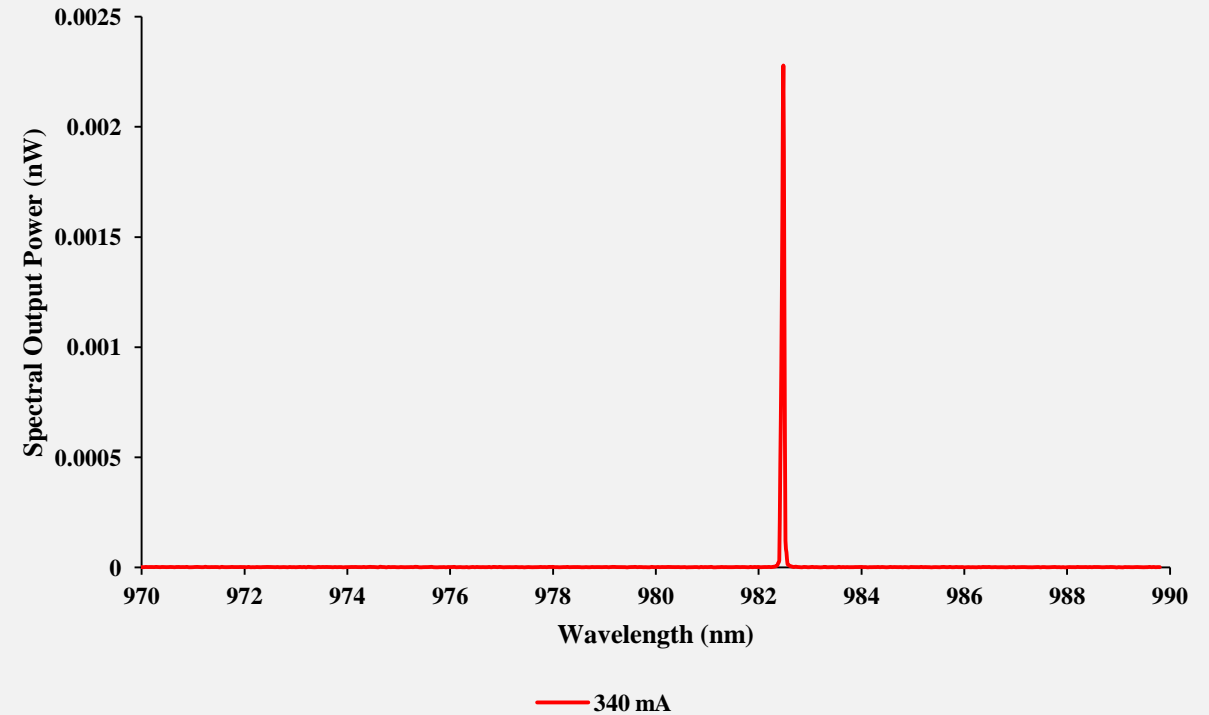

Model Number: APS-980nm-250mW-STM-9.0mm-CC

Module Dimensions and Mounting Screws

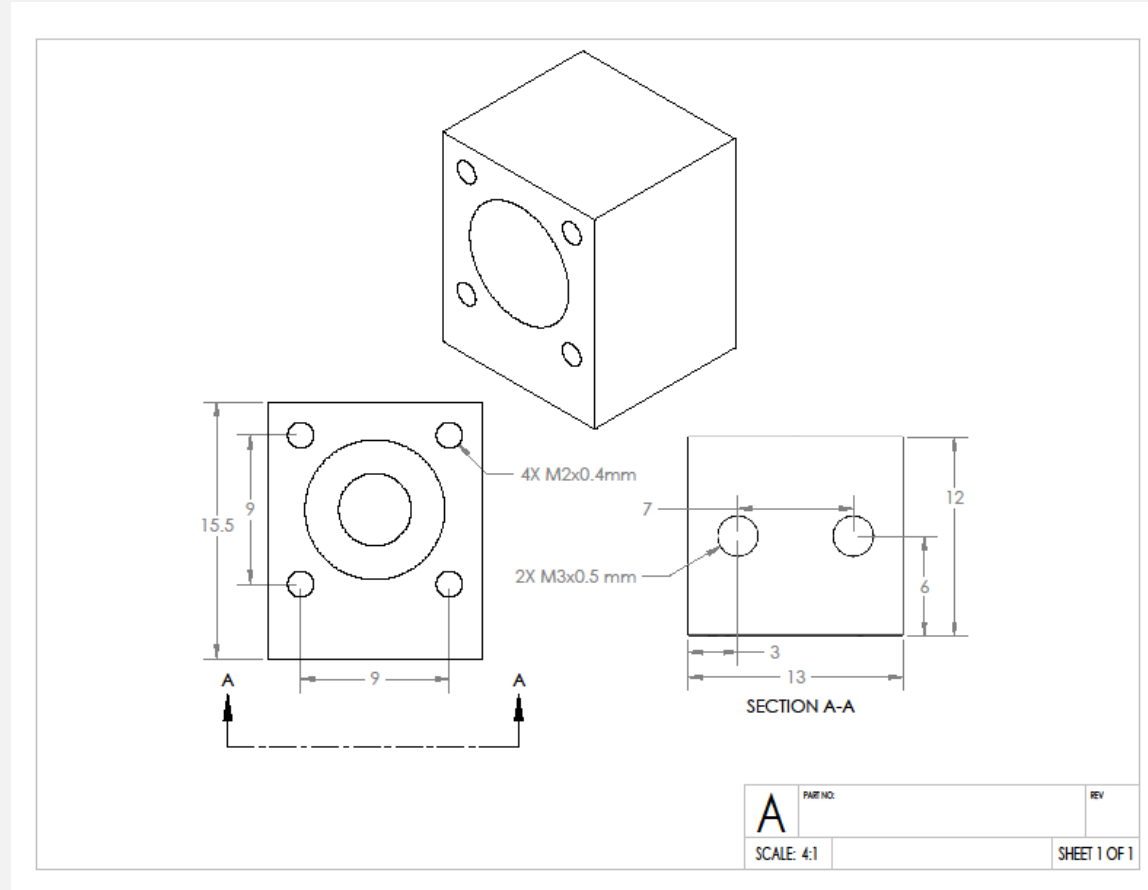



Model Number: APS-980nm-250mW-STM-9.0mm-CC

Laser Safety Warnings

- **This OEM Micro-Module is meant for integration into other systems, and as such is not CDRH compliant.**
- **This Micro-Module is a Class IIIB laser product.**
- **Always use laser safety glasses with sufficient Neutral Density at the operating wavelength of 980 nm to protect your eyes.**
- **Skin exposure to this laser product should be avoided.**