



Model Number: APS-639nm-30mW-STM-5.6mm-APC

APS 30 mW 639 nm Laser Diode Module With Adjustable Aspheric Collimating Lens

Absolute Maximum Ratings at 25 °C

Item	Ratings	Unit
CW Output Power	30	mW
Laser Diode Reverse Voltage	2	V
Maximum Operating Current	130	mA
Operating Temperature	-10 to 50	°C
Storage Temperature	-40 to 85	°C

- **Simple Integrated Package**
- **Excellent Diode Heatsinking**
- **Small Footprint**
- **Simple Connection With Two Power Leads**
- **Adjustable Collimating Lens**
- **Lightweight, Rugged**
- **Precision Machined**

**Applications: Pointing, Laser Leveling,
Alignment, Bar Code Reader**





Model Number: APS-639nm-30mW-STM-5.6mm-APC
APS 30 mW 639 nm Laser Diode Module With Adjustable Aspheric Collimating Lens

Optical and Electrical Characteristics at 25 °C

Parameter	Min	Typical	Max	Units	Test Condition
Threshold Current	30	45	65	mA	-
Operating Current	-	95	130	mA	$P_o = 30 \text{ mW}$
Operating Voltage	-	2.3	2.8	V	$P_o = 30 \text{ mW}$
Fast Axis Beam Divergence	44	51	58	°	$P_o = 30 \text{ mW}$ 1/e ² Full Angle
Slow Axis Beam Divergence	12	15	19	°	$P_o = 30 \text{ mW}$ 1/e ² Full Angle
Lasing Wavelength	630	636	640	nm	$P_o = 30 \text{ mW}$
Transverse Mode	STM	STM	STM	-	All Currents
Polarization TE	-	-	-	-	Horizontal

Module Experimental Data

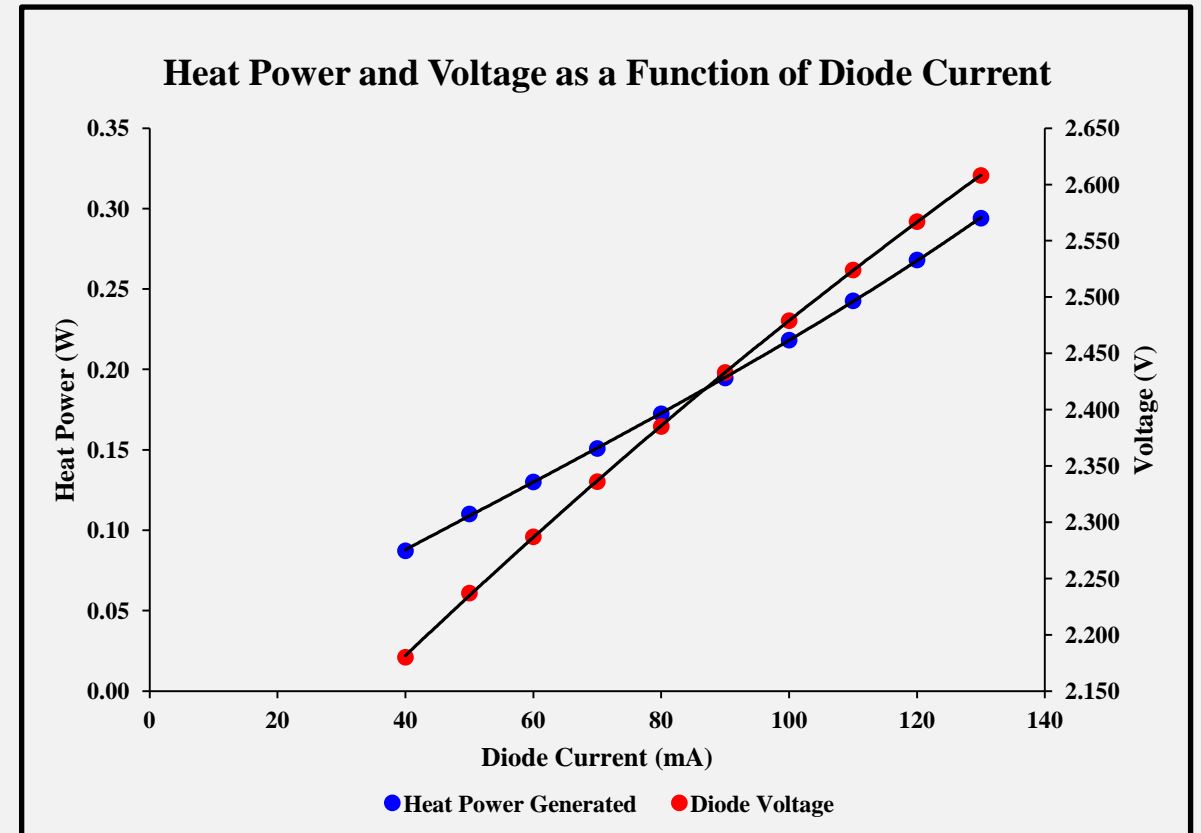
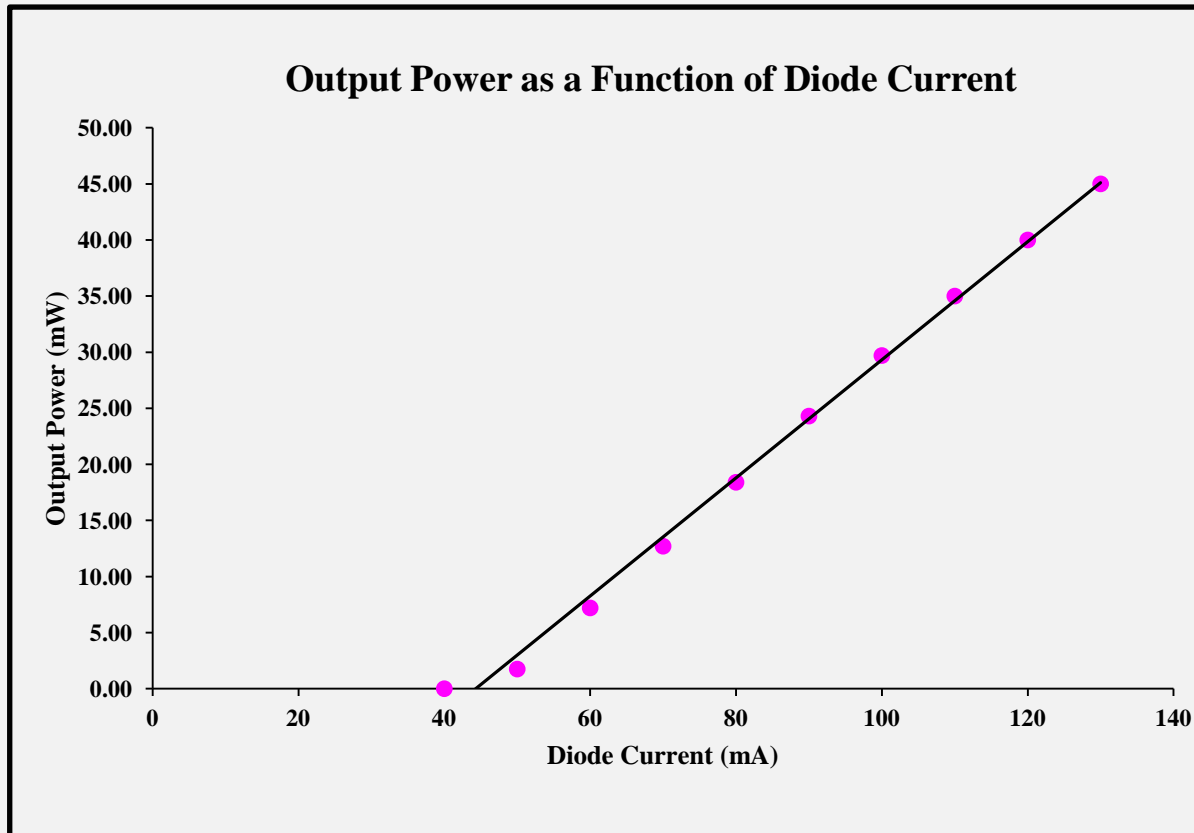

Module Experimental Data

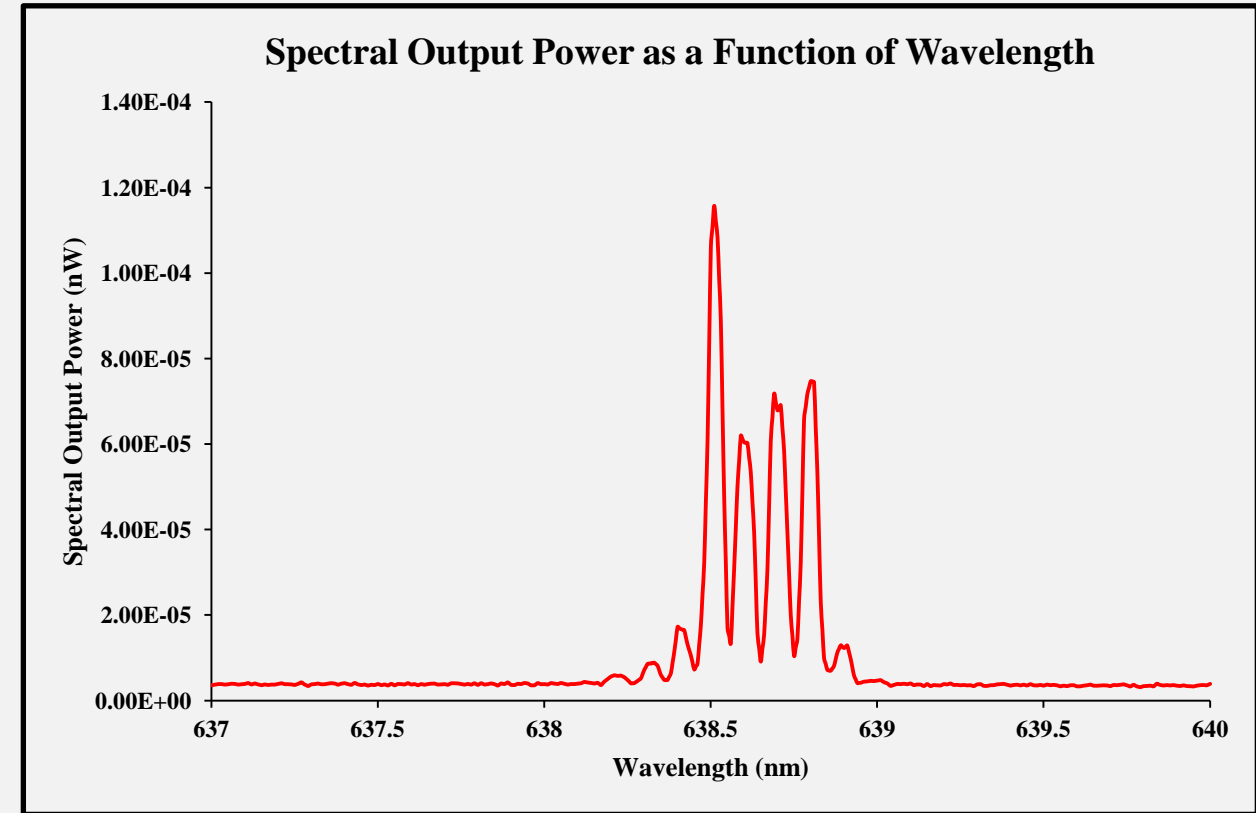
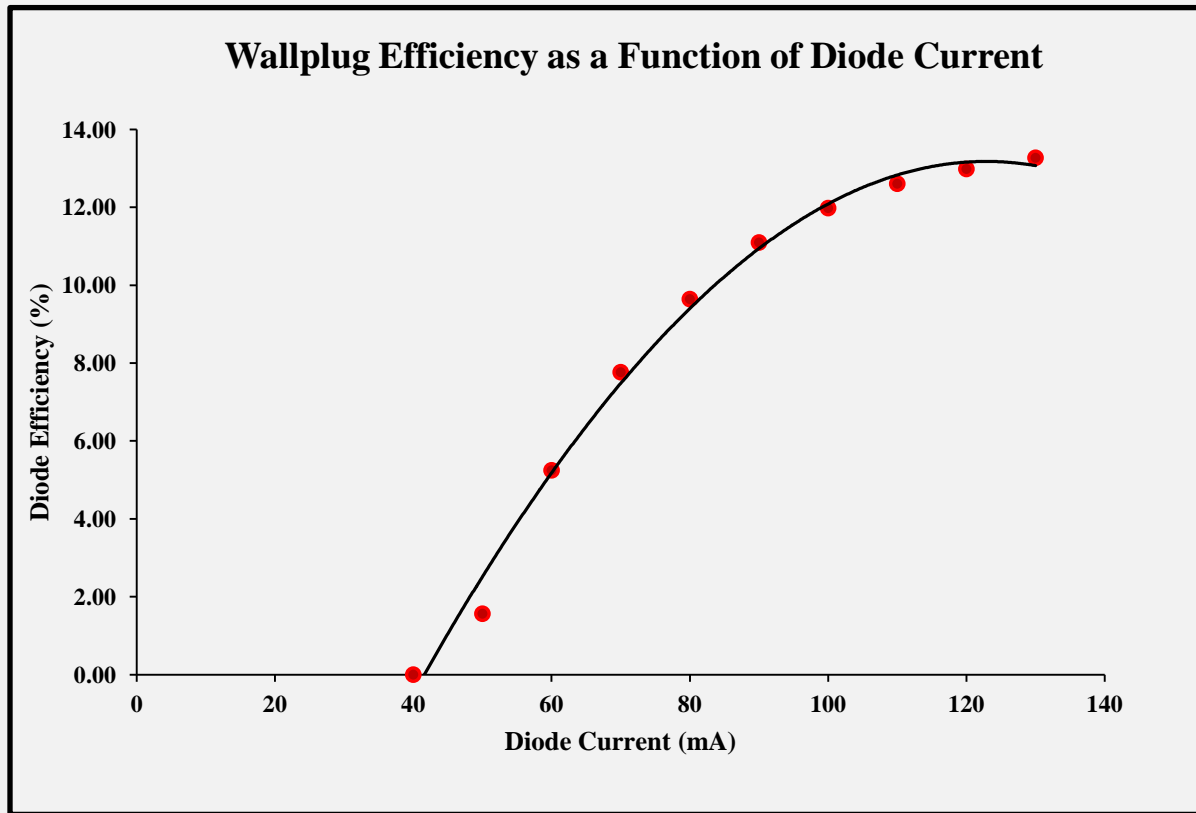

Model Number: APS-639nm-30mW-STM-5.6mm-APC

Module Dimensions and Mounting Screws

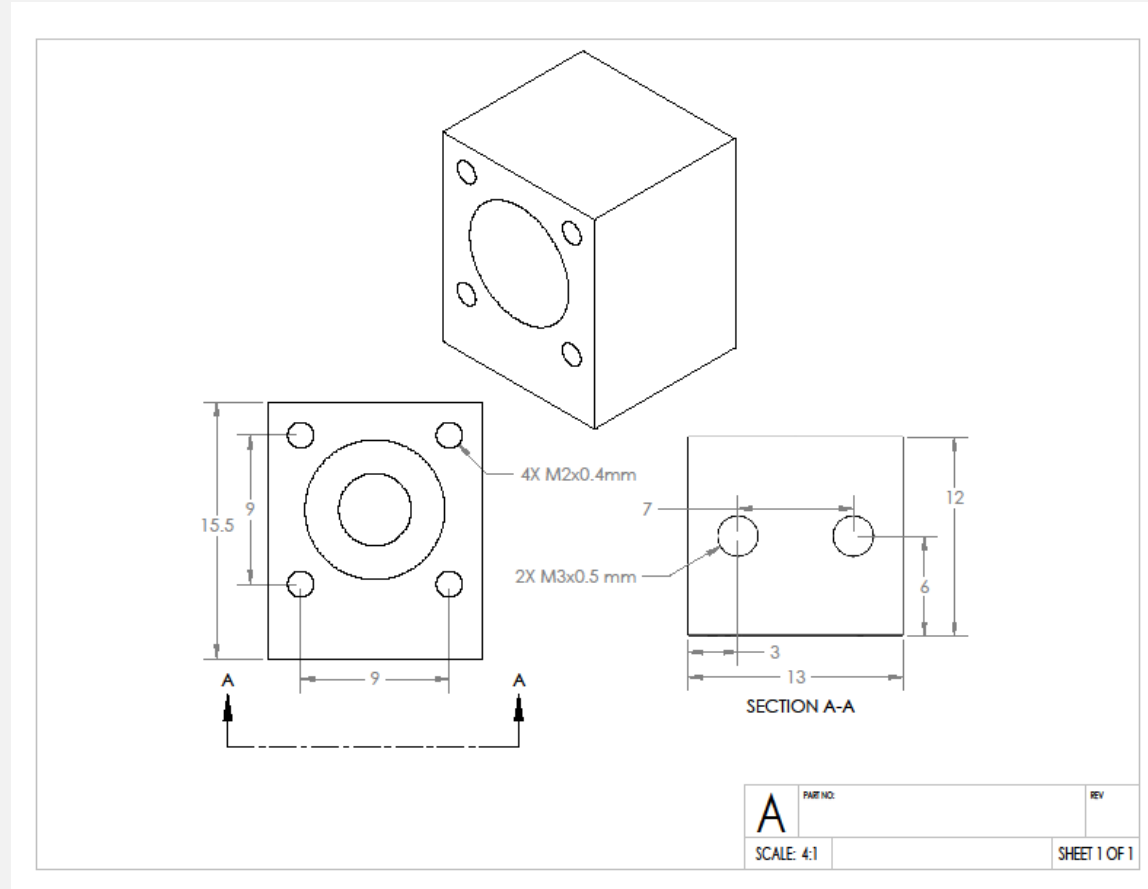



Model Number: APS-639nm-30mW-STM-5.6mm-APC

Laser Safety Warnings

- **This OEM Micro-Module is meant for integration into other systems, and as such is not CDRH compliant.**
- **This Micro-Module is a Class 3B laser product.**
- **Always use laser safety glasses with sufficient Neutral Density at the operating wavelength of 639 nm to protect your eyes.**
- **Skin exposure to this laser product should be avoided.**